

Overview

The BA/T#-A is a flexible averaging duct mounted 4-20mA or Voltage transmitter probe. It comes in a variety of probe lengths and optional mounting enclosures shown below. The 4-20mA transmitter can be ordered with 100Ω (385), 1KΩ (385) RTDs or 10KΩ type 2 thermistor sensors. A 0-5VDC or 0-10VDC transmitter is also available with the 10KΩ type 2 thermistor sensor. Special high accuracy RTD matched transmitters (M) are available which match the sensor to the transmitter for improved accuracy.

Identification

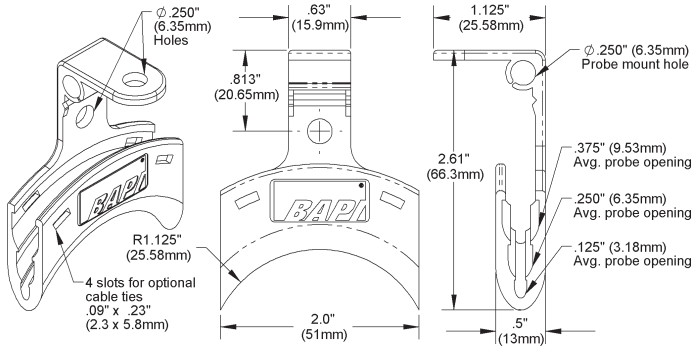

Fig 1: Flexible Probe Bracket (BA/FPB)
(Order Separately)

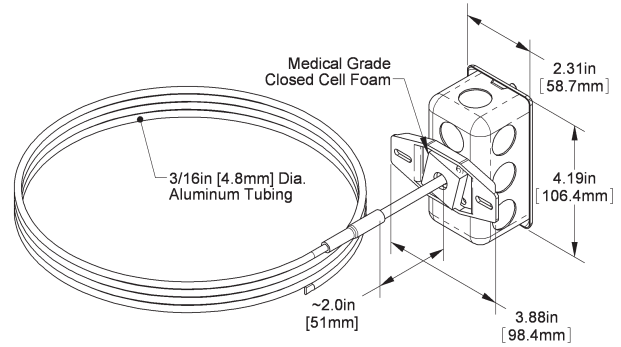

Fig 2: Duct Averaging Unit with J-Box (Standard)

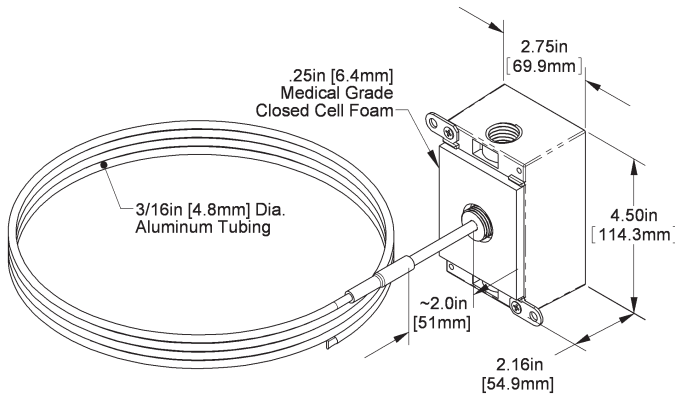

Fig 3: Duct Averaging Unit with Weatherproof (WP) Enclosure

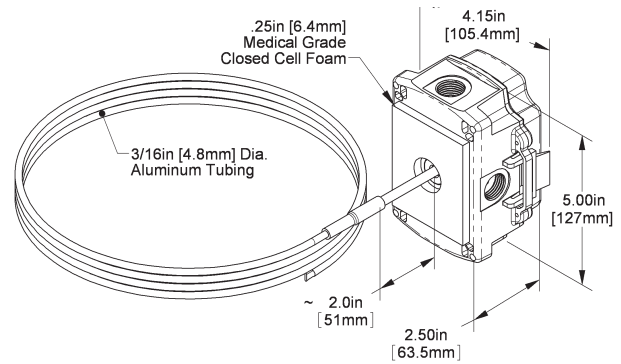

Fig 4: Duct Averaging Unit with BAPI-Box (BB) Enclosure

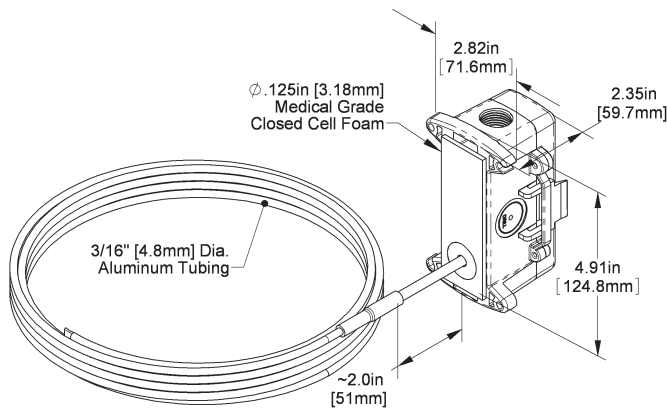

Fig 5: Duct Averaging Unit with BAPI-Box 2 (BB2) Enclosure

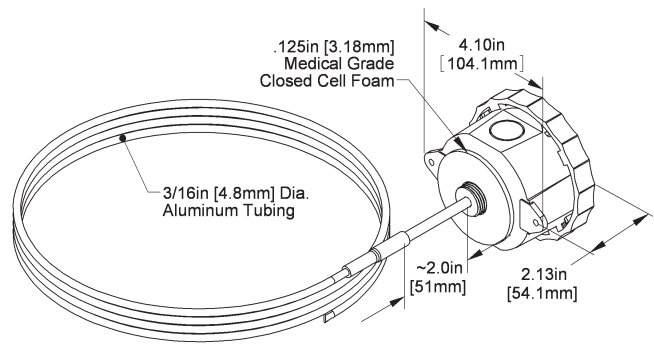

Fig 6: Duct Averaging Unit with Weather Tight (EU) Enclosure

Specifications subject to change without notice.

Mounting

1. Place the sensor in the middle or top of the duct as shown in Fig. 7 or Fig. 8 so the flexible probe can enter the duct in a convenient place. Drill the probe and mounting holes as depicted for the enclosure being used. (**Handy Box, BB, BB2, WP, EU**).
2. Insert the probe by unrolling the sensor into the duct carefully to avoid kinking the sensor. Serpentine the duct with the sensor at least twice across the stratified air in the duct to achieve the best average temperature reading. At the sensor reversing points a BAPI Flexible Probe Bracket (BA/FPB - order separately) can be used to support the sensor and to avoid kinking the sensor.
3. Mount the enclosure to the duct using BAPI recommended #8 screws through a minimum of two opposing mounting tabs provided. Weatherproof (WP) enclosures will require assembly of the mounting tabs on opposite corners. A 1/8 inch pilot screw hole in the duct makes mounting easier through the mounting tabs. Use the enclosure tabs to mark the pilot hole locations.
4. Snug up the sensors so that the foam backing is depressed to prevent air leakage but do not over-tighten or strip the screw threads.

Note 1: Be sure not to drill into the weatherproof enclosures (**BB, BB2, WP, EU, EUO**) which will violate the NEMA and/or the IP rating.

Note 2: Be sure to use caulk or Teflon tape for your conduit entries to maintain the appropriate NEMA or IP rating for your application.

Note 3: Conduit entry for outdoor or wet applications should be from the bottom of the enclosure.

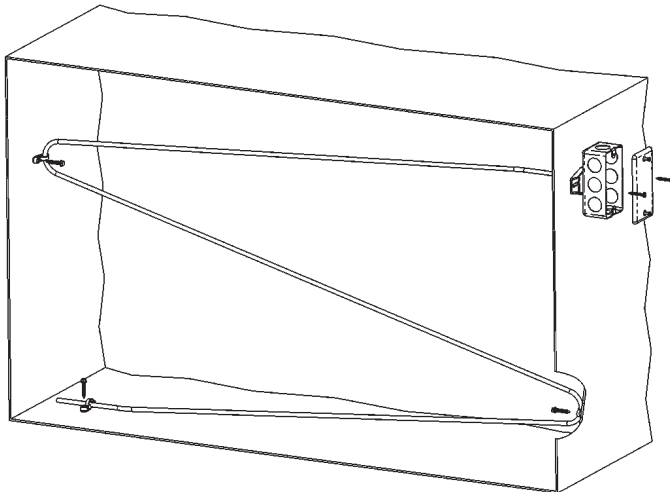

Fig 7: Averaging Sensor Horizontal Mount. Best for Vertical Stratification.

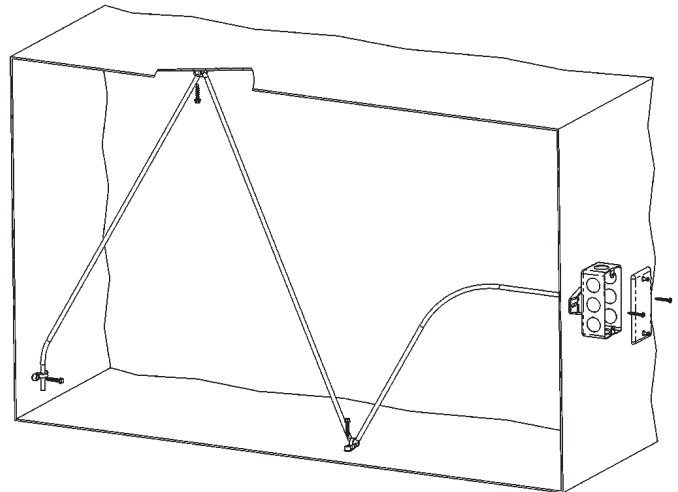

Fig 8: Averaging Sensor Vertical Mount. Best for Horizontal Stratification.

Mounting Continued

Mounting Notes:

Note 1

Be sure not to drill into the weatherproof enclosures (**BB, BB2, WP, EU, EUO**) which will violate the NEMA and/or the IP rating.

Note 2

Be sure to use caulk or Teflon tape on all threaded openings to maintain the appropriate NEMA or IP rating for your application.

Note 3

Conduit entry for outdoor or wet applications should be from the bottom of the enclosure.

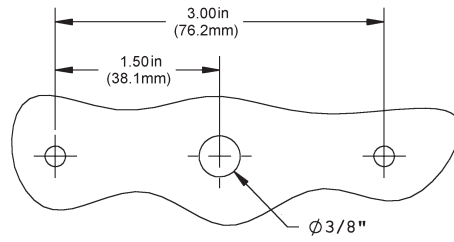

Fig 9:
 Junction Box or No-Box (**NB**)
 Mounting Holes

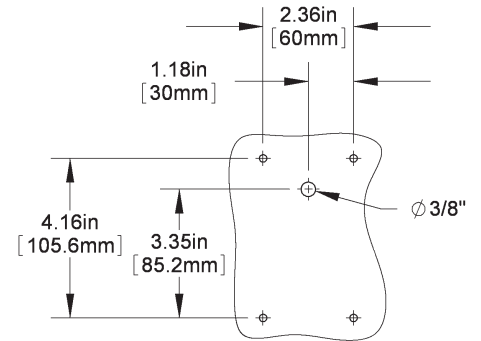
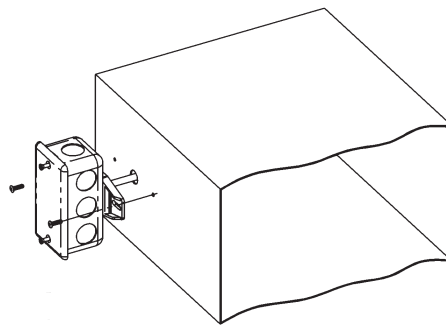

Fig 10: BAPI-Box 2 (BB2)
 Enclosure Mounting Holes

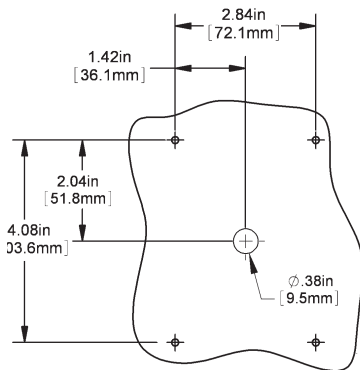
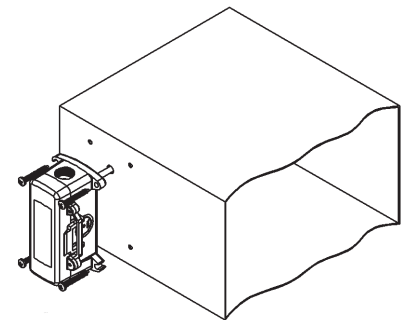

Fig 11: BAPI-Box (BB) Enclosure
 Mounting Holes, Rotate 90° for
 Horizontal Mounting

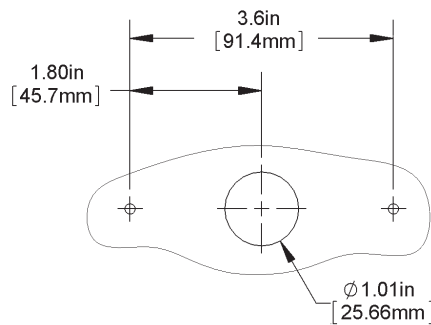
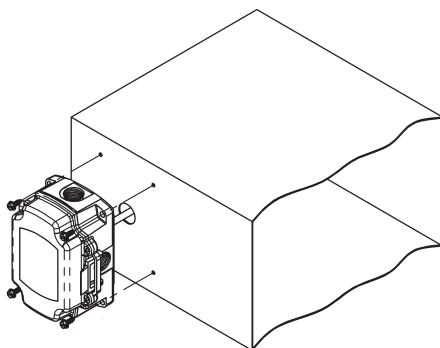

Fig 12: Weather Tight (EU or EUO)
 Enclosure Mounting Holes

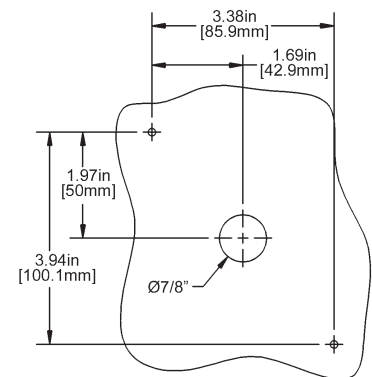
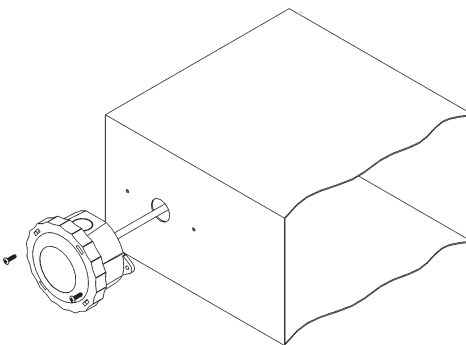
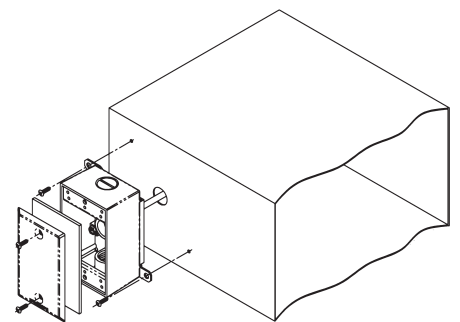

Fig 13: Weatherproof (WP)
 Enclosure Mounting Holes



Specifications subject to change without notice.

Wiring & Termination

BAPI recommends using twisted pair of at least 22AWG and sealant filled connectors for all wire connections. Larger gauge wire may be required for long runs. All wiring must comply with the National Electric Code (NEC) and local codes. Do NOT run this device's wiring in the same conduit as high or low voltage AC power wiring. BAPI's tests show that inaccurate signal levels are possible when AC power wiring is present in the same conduit as the sensor wires.

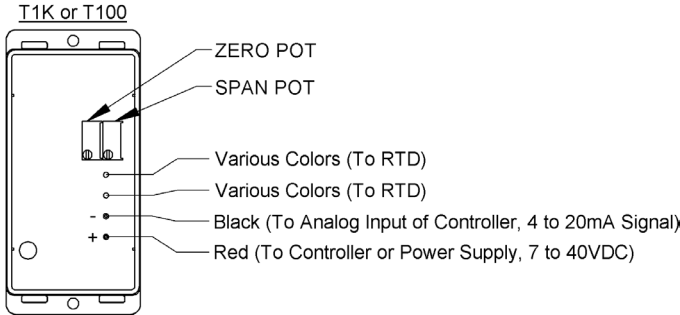

Fig. 14: Typical RTD 4 to 20 mA Transmitter with Flying Leads

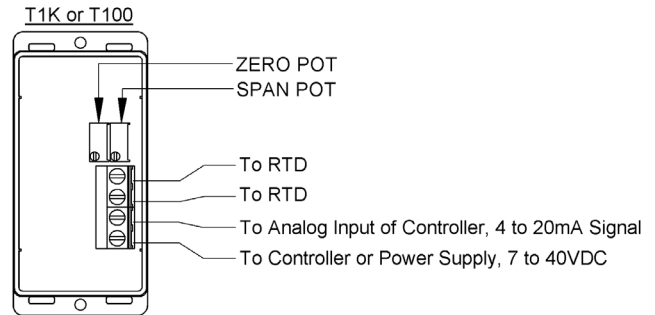

Fig. 15: Typical RTD 4 to 20mA Transmitter with Terminals

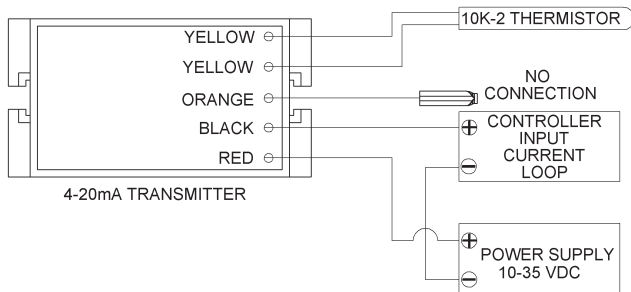

Fig. 16: Typical Thermistor 4 to 20mA Transmitter

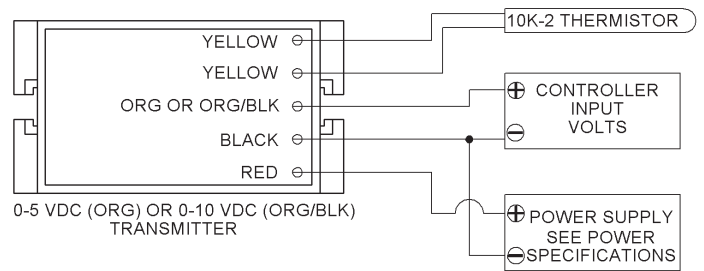

Fig. 17: Typical Thermistor Voltage Transmitter

Diagnostics

Possible Problems:

- Unit will not operate.

Possible Solutions:

- Measure the power supply voltage by placing a voltmeter across the transmitter's (+) and (-) terminal. Make sure that it matches the drawings above and power requirements in the specifications.
- Check if the RTD wires are physically open or shorted together and are terminated to the transmitter.
- Measure the physical temperature at the temperature sensor's location using an accurate temperature standard. Disconnect the temperature sensor wires and measure the temperature sensor's resistance with an ohmmeter. Compare the temperature sensor's resistance to the appropriate temperature sensor table on the BAPI website.

- The reading is incorrect in the controller.

- Determine if the input is set up correctly in the controllers and BAS software.
- For a 4-20mA current transmitter measure the transmitter current by placing an ammeter in series with the controller input. The current should read according to the "4-20mA Temperature Equation" shown below.
- For a voltage transmitter, measure the signal with a volt meter (Orange or Orange/Black to Black). The signal should read according to the "Voltage Temperature Equation" shown below.

Voltage Temperature Equation

$$T = T_{Low} + \frac{(V \times T_{Span})}{V_{Span}}$$

T = Temperature at sensor
 T_{Low} = Low temperature of span
 T_{High} = High temperature of span
 T_{Span} = T_{High} - T_{Low}
 V_{Low} = Low transmitter voltage usually=(0, 1 or 2v)
 V_{High} = High transmitter voltage usually=(5 or 10v)
 V_{Span} = V_{High} - V_{Low}
 V = Signal reading in volts

4-20mA Temperature Equation

$$T = T_{Low} + \frac{(A - 4) \times (T_{Span})}{16}$$

T = Temperature at sensor
 T_{Low} = Low temperature of span
 T_{High} = High temperature of span
 T_{Span} = T_{High} - T_{Low}
 A = Signal reading in mA

Specifications subject to change without notice.



Specifications

RTD Transmitter

Power Required:	7 to 40VDC
Transmitter Output:	4 to 20mA, 850Ω@24VDC
Output Wiring:	2 wire loop
Output Limits:	<1mA (short), <22.35mA (open)
Span:	Min. 30°F (17°C), Max 1000°F, (555°C)
Zero:	Min. -148°F (-100°C), Max 900°F (482°C)
Zero & Span Adjust:	10% of span
Accuracy:	±0.065% of span
Linearity:	±0.125% of span
Power Output Shift:	±0.009% of span
RTD Sensor:	2 wire Platinum (Pt), 385 curve
Transmitter Ambient:	-4 to 158°F (-20 to 70°C) 0 to 95% RH, Non-condensing

Thermistor Transmitter

Supply Voltage:	
10 to 35 VDC	0 to 5 VDC or 4 to 20 mA Outputs
15 to 35 VDC	0 to 10 VDC Output
12 to 24 VAC	0 to 5 VDC Outputs
15 to 24 VAC	0 to 10 VDC Output
Transmitter Output	4 to 20mA, 700Ω@24VDC 0 to 5VDC, 0 to 10VDC, 10KΩ min
Output wiring	2 & 3 wire (see Wiring detail)
Transmitter Limits	-40°F to 185°F, (-40°C to 85°C)
Accuracy	±1.015°C, from (0 to 65°C)
Linearity	±0.065°C, from (0 to 65°C)
Resolution	Span/1024
Thermistor Sensor	10K-2 Thermistor, 10KΩ @77°F
Transmitter Ambient	32 to 158°F, (0° to 70°C) 0 to 95% RH, Noncondensing 10K-2, Thermal resistor

Thermistor:

Sensor Probe:	
8 feet	4 Thermistors
12 feet	4 Thermistors
24 feet	9 Thermistors
Accuracy	(Std) ±0.36°F, (±0.2°C)
Accuracy	(High) ±0.18°F, (±0.1°C), [XP] option
Stability	< 0.036°F/Year, (<0.02°C/Year)
Heat Dissipation	2.7 mW/°C
Probe Range	-40° to 221°F (-40° to 105°C)
Wire Colors:	
Standard:	Yellow/Yellow (no polarity)
High Acc. [XP]:	Yellow/Yellow (no polarity)

RTD:

Platinum (Pt)	Resistance Temp Device (Continuous)
Pt Accuracy	100Ω and 1KΩ @0°C, 385 curve, (Std) 0.12% @Ref, or ±0.55°F, (±0.3°C)
Pt Accuracy	(High) 0.06% @Ref, or ±0.277°F, (±0.15°C), [A]option
Pt Stability	±0.25°F, (±0.14°C)
Pt Self Heating	0.4 °C/mW @0°C
Pt Probe Range	-40° to 221°F, (-40 to 105°C)
Wire Colors:	General color code (other colors possible)
1KΩ, Class B	Orange/Orange (no polarity)
1KΩ, Class A	Orange/White (no polarity)
100Ω, Class B	Red/Red (no polarity)
100Ω, Class A	Red/Red-w/black stripe (no polarity)

Sensitivity: Approximate @ 32°F (0°C)

Thermistor	Non-linear (see www.bapivac.com, click "Sensor Specs")
RTD (Pt)	3.85Ω/°C for 1KΩ RTD 0.385Ω/°C for 100Ω RTD
Lead wire	22awg stranded
Insulation	Etched Teflon, Plenum rated
Probe	Flexible Aluminum tube, 0.19"OD
Probe Length	8', 12', 24' per order
Duct gasket	1/4" Closed cell foam (impervious to mold)
Mounting	Extension tabs (ears), 3/16" holes

Enclosure Types: (Part number designator in bold)

J-Box:	-JB , w/ eight 1/2" knock-outs
Weatherproof:	-WP , w/ two 1/2" FNPT entries, (Bell box)
BAPI-Box:	-BB , w/ four 1/2" NPSM & one 1/2" drill-out
BAPI-Box 2:	-BB2 , w/ three 1/2" NPSM & three 1/2" drill-outs
Weather Tight:	-EU, EUO , w/ two 1/2" knock-outs

Enclosure Ratings: (Part number designator in bold)

J-Box:	-JB , NEMA 1
Weatherproof:	-WP , NEMA 3R, IP14
BAPI-Box:	-BB , NEMA 4, IP66, UV Rated
BAPI-Box 2:	-BB2 , NEMA 4, IP66, UV Rated
Weather Tight:	-EU , NEMA 4, IP66
Weather Tight:	-EUO , NEMA 4, IP66, UV rated

Enclosure Material: (Part number designator in bold)

J-Box:	-JB , UL94H-B
Weatherproof:	-WP , Cast Aluminum, UV rated
BAPI-Box:	-BB , Polycarbonate, UL94V-0, UV rated
BAPI-Box 2:	-BB2 , Polycarbonate, UL94V-0, UV rated
Weather Tight:	-EU , ABS Plastic, UL94V-0
Weather Tight:	-EUO , ASA (Geloy) Plastic, UL94V-0, UV rated

Ambient (Encl.)

J-Box	-JB , -40°F to 212°F, (-40° to 100°C)
Weatherproof	-WP , -40°F to 212°F, (-40° to 100°C)
BAPI-Box	-BB , -40°F to 185°F, (-40° to 85°C)
BAPI-Box 2	-BB2 , -40°F to 185°F, (-40° to 85°C)
Weather Tight	-EUO, EU , -40°F to 185°F, (-40° to 85°C)

Agency

RoHS	
PT=DIN43760, IEC Pub 751-1983,	
JIS C1604-1989	